HOW TO BUILD AN
ACCESSIBLE ENVIRONMENT
IN DEVELOPING COUNTRIES

Based on the Cambodia
Program's experience



Manual #1 -
Introduction &
Accessibility standards

Handicap International

HOW TO BUILD AN ACCESSIBLE ENVIRONMENT IN DEVELOPING COUNTRIES



Manual # 1 – Introduction & Accessibility standards



République
et Canton
de Genève



Published in:

December 2008

Published by:

Handicap International France, Cambodia Program

#6, St. 348,

BKK3, Chomkarmon, Phnom Pemh

office@hicambodia.org

Content developed by:

Vincent DAVID, Cambodia, Accessibility and Infrastructures Coordinator

Supervised by:

Ulrike LAST, Cambodia, Inclusion & Rights Coordinator

Lucile PAPON, Cambodia, Program Director

Eric PLANTIER ROYON, Head Quarters, Accessibility Technical Advisor

Design, layout and translation:

Eric JARLÉGAN

Photographs and illustrations credits:

© Handicap International – French Section

The technical content developed in this set of manuals is the property of Handicap International. You can use its content, such as technical drawings, estimations, etc. freely, provided that you cite HI's manual as the source.

Handicap International cannot be held responsible for any misuse of the content.

Table of contents

Foreword	6
Introduction	9
Aim and targeted audience	12
What is accessibility?	13
Common misconceptions and mistakes	14
Local accessibility planning	16
Accessibility and UN Convention	18
Handicap International approach	20
Cambodian legal framework	21
International standards	23
“Standards” used by HI for the built environment	24
Standardised vs. individualised approach	36

Foreword

As Country Director of Handicap International in Cambodia, I'm pleased to introduce the set of manuals "How to build an accessible environment". The primary objective of this guide is to promote the idea of and practices for an inclusive society as an integral part of the development of Cambodia. But what means an inclusive society? It means an environment that can be lived in, used and enjoyed by everyone, regardless of age, gender and/or disability. Surely, to accomplish such a society necessitates a long breath and actions. The environment accompanying it would be shaped by elements such as society's and individual's attitudes, recognizing and accommodating differences. Meaningful inclusion is for the benefit of all. It enables each and everyone to participate in the social, economic, religious and cultural life equally and with dignity.

Handicap International is fully committed to an inclusive society in which nobody is disadvantaged. An important part of making this commitment a reality is promoting the removal of unnecessary physical barriers and hindrances to an independent life imposed on disabled people. What are those hindrances and barriers? By account of disabled people they are poor designs of buildings and places. Stairs are not an entry but preventing you from entering, if you are a wheel chair user. Sanitation facilities allowing for increased hygiene, if not constructed with disabled people in mind are causing hygienic problems to them. A separate ramp at the back of the building makes the one using it feel excluded and separated from the mainstream. Too often such feedback and requirements of disabled people are considered late in the day and separately from those of the others. **We want to support disabled people to change that.**

A common misconception is that adapting or building accessible environments is a costly exercise. Developers and keys actors often use this argument to justify the absence of accessibility. From our perspective also the lack of legislations or missing consideration given to disabled people are contributing to the widespread absence of inclusive designs.

Current challenges for inclusive environments in public spaces in Cambodia are for instance the lack of clear regulations for building and construction permits and that the legislation on disability remains in voting process only. However, the Royal Government of Cambodia by signing the **UN Convention for the rights of people with disabilities** in 2007 as well as the **Biwako Millennium Framework** showed strong signals of commitment and consideration for disabled people as equal citizens. With this manual we would like to support concerned parties, such as the Royal Government of Cambodia, the private construction sector and/or civil society organizations to make adaptations to the built environment. Changes in our external environment can be achieved at a minimal cost with creative thinking and careful consideration of people's needs.

Improving access to the physical environment results in greater social equity; it is thus a question of choice: which society do we want for us and our children? Enabling disabled people to participate better in social, economic, cultural and religious activities by dismantling physical barriers will result in a more democratic and powerful society.

Many thanks to the persons who contributed to it: Vincent David (Technical Referent), Eric Jarlégan (Concept and Design), Ulrike Last (Inclusion & Rights Coordination), Mr. Srun and the Battambang team for Cambodia mission; Eric Plantier – Royon (Technical Referent) for head quarters – Our donors **The Canton of Geneva** and the **MAAIONG – French Embassy SCAC** in Cambodia.

I hope that you will find this guide useful and encouraging for creating buildings and places which all people can use with dignity and confidence.

Phnom Penh, November 2008

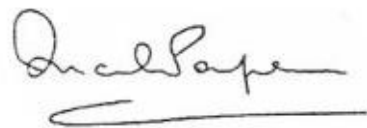

Lucile Papon (Mrs), Country Director
Handicap International – French Section

Acronyms and abbreviations

DPO	Disabled People Organization
HI	Handicap International
PwD	Person(s) with disability(ies)
UN	United Nations
Watsan	Water and sanitation
NGO	Non Governmental Organization
UXO	Unexploded Ordnance

Introduction

Cambodia is a country with a current population of approximately 14 million. It was devastated by almost 30 years of civil conflict, war and genocide. This has resulted in serious losses of human resources and destruction of its physical & administrative infrastructure. The Kingdom, in a recovery process, has benefited from major international financial and technical support on infrastructures building, governance, health and education sectors, etc.

Despite the lack of confirmed data (ref. 4.5%) **Cambodia is often cited as a country with high numbers of disabled inhabitants**; added to the “common” forms of impairments (caused by diseases and malnutrition, accidents, motherhood & childhood risks) and disability (caused by discrimination and negative attitudes and physical barriers), is the plague of Mines/UXOs. The latter has deeply affected the population and the economical development.

Despite their visibility and the commitment of the authorities to build an inclusive society, people with disabilities still suffer severely from the every day lack of accessibility in their country. The mobility possibilities for people with disabilities remain very poor. The roads are not equipped for disabled people, especially not for people using wheelchairs, crutches or white canes. This includes the pavements, the traffic lights, and public roads due to obstructions, uneven and unpaved surfaces, steps, and such alike. Public transportation is not really existing, and private buses hardly accessible. It is almost impossible for people in wheelchairs and people walking with crutches to get on a bus. Higher-level institutions typically have several flights of stairs. The majority of public buildings, hospitals and schools are inaccessible as well. Most of the buildings do not have ramps, handrails or any other support systems. Corridors, toilets and bathrooms are often so narrow or tiny that they are inaccessible. Visually and hearing impaired people are predominantly deprived when it comes to accessing information that is important to them. This lack of access to information has serious effects on people with disabilities’ welfare, safety, health, life opportunities and the full enjoyment of their rights. Furthermore,

negative attitudes and discrimination have created a wide range of barriers. Those barriers have denied many disabled people opportunities to access employment, education, resources and/or even to participate in social and cultural practices.

The 15-year long experience in Cambodia provided us with ample opportunities to observe how the vicious circle of poverty – disability – exclusion endures when accessibility is denied. In 2004, Handicap International initiated actions of constructing inclusive buildings for people with disabilities within the Education for All project. **23 schools, playgrounds and water points, 6 public buildings (health centers...) and 56 individual homes were targeted, adapted and made inclusive.**



Srey Andong Pi School in the Samlot district of Cambodia

Moreover, the **comprehensive approach** of HI lead to work on the environmental factors limiting the integration of disabled children. Environmental factors in focus for change through the different project are: physical ones (roads, stairs...), political ones (laws, stakeholders behaviors) or social ones (services, micro credit...). Partners in such action are foremost people with disabilities and their organizations, next to the government and other civil society organizations.

In conclusion, when analyzing the Cambodian environment with regards to accessibility & disability, two main perspectives need to be considered: **access to** and **accessibility of** the built environment. **Access to** the built environment includes the possibility of all people to reach all places within the already built environment.

Accessibility of the built environment includes the possibility of all people to maneuver and make use of the built environment as independent as possible. The present guideline will mainly focus on this second perspective: to contribute guaranteeing that disabled people can enjoy highest autonomy, given their impairment and that they can fully participate in society.

NOTE

We must underline the fact that all the contents and figures present in these different manuals aim only to give ideas and examples of some realizations made by Handicap International, and should **be used for construction with a technical validation first**. The association declines all responsibility in case of accident/misconstruction after using the technical recommendations introduced by these manuals.

Aim and targeted audience

This guideline's purpose is to promote understanding and knowledge on accessibility standards and techniques. It emphasizes the importance to include, from the start of work's design, the accessibility issue. This guideline allows also technical recommendations adapted to developing countries' contexts, as well as helping to calculate the costs and make design decisions.

As the introduction reminds of the key principles and references to disability, the 3 following booklets on effective implementation of accessibility respectively:

- **explain** relevant legislation and policy frameworks,
- **show how** developers can put in place appropriate planning policies,
- and **provide** technical and culturally adapted (in Cambodia) advises.

Special attention has been paid to the **targeted audience**. The chosen option to conciliate policies and technical aspects addresses a broad range of audience from the government to the private, including:

- planning stakeholders at development and policy level,
- construction developers,
- architects and designers,
- Logistic actors: NGO coordinators, logisticians, etc.,
- Users and organizations of the public, particularly disabled people, elderly people, women, children, parents, caregivers and anyone disadvantaged through poor design.

What is accessibility?

There are many different definitions of accessibility depending on how you see it. According to Handicap International, **an accessible environment must allow for free and safe movement, function and access for all, regardless of age, sex or condition.** It is a space or a set of services that can be accessed by all, without obstacles, with dignity and with as much autonomy as possible.

Thus, accessibility is taken in a very general way, and some themes can be considered:

- **Accessibility of the built environment**, which includes housing and private buildings, as well as public spaces or buildings.
- **“Geographic accessibility”**, which looks at the ability to circulate: everybody should have the right and the opportunity to choose their means of transport, to go from one place to another according to their needs, abilities and budget (this dimension can be understood together with the previous one, but experience shows that in many cases free movement has to be addressed per se in addition to the settings and buildings themselves).
- **Access to information and communication** (accessible media, accessible dissemination of information and accessible messages).

It is important to note that accessibility in its broadest sense, which can be called “social accessibility” (access to credit, to employment, to sport and leisure...) is not included in the definition that we use here. It is more a question of inclusion in a general way.

The universal design, an inclusive way of conceiving accessible facilities

An accessible environment that is to be used by everyone, the best way to do it is to think using the concept of “universal design”. The idea behind Universal Design is that any space, building, product, service as well as information are designed in a way to be accessible, usable, understandable and comfortable for all people without discrimination.

Activities carried out by Handicap International are directly inspired by the concept of Universal Design. The most inclusive solution must be found: for instance a public building with a smooth slope at its main entrance will be more suitable for all, than a staircase for non-disabled people and a ramp for disabled persons. What this concept implies is that spaces should not be adapted but should be built in a way that meets the needs of all people, including people with disabilities.

Universal design principle should be applied for all public buildings, all public facilities and all public features. Making accessible housing or work places must be thought considering the specific impairments of each person concerned. This way, the work goes along with ergonomics (housing or work place adaptation), and is based on an accurate diagnostic of the person's situation.

Common misconceptions and mistakes about accessibility

In the field of accessibility, there are **many misconceptions** that can lead one not to consider it when building an infrastructure of any type, such as:

◇ “To build an accessible infrastructure is very expensive”: if taken into account during the conception phase, accessibility represents **an overcost of no more than 2%** of the total cost of the building. The problem is that when accessibility is not taken in consideration at the beginning of a project, the cost to implement it afterwards can be much more considerable. For a basic but unfortunately not too uncommon example, you can think about the case of the installation of a lift in a building that was built without a well for it. In any case, some cheap and simple layouts can be set

up in order to greatly improve the accessibility of an infrastructure. In addition, building an accessible environment will allow the social and economic inclusion of PwDs in the society (they are consumers and workers like the others). A World Bank study estimates the annual loss of GDP globally, due to PwDs being excluded from economic income activities, at between US\$1.37 trillion and US\$ 1.94 trillion. So even if it costs a little at the beginning, **implementing accessibility will be at the end a factor of wealth creation.**

◇ “There is no point considering the needs of people with disabilities when building a new infrastructure, there are so few of them”: people living with disabilities are citizens like others, and should have the same rights. This is why all the services they may need and use should be made accessible to them.

Who is benefitting from accessibility

It is very important to underline the fact that an accessible infrastructure will not only benefit people with disability but a **wide range of people** such as elders who have difficulties to move, pregnant women and young mothers, people with cardiac problems, persons carrying heavy burdens, people with a broken leg... Anyone can be part of one of these categories sooner or later in his life. Accessibility thus concerns a much larger public than only people living with disability, and must be considered at all cost when building a new infrastructure.

◇ “To make an infrastructure accessible, you just have to build a ramp at the entrance”: it is a big mistake to think that accessibility can be provided by only a ramp. As we have seen in the previous box, **accessibility concerns a very wide range of people**, and a ramp will only help people with a reduced mobility, especially persons in a wheelchair.

Even if you build a ramp, maybe the interior layout of the building will prevent wheelchair users to circulate in it, or it will not be suited for the orientation of sightless people, or the main services will be at the top floor and the building does not offer an elevator... This is why **you have to think in terms of Universal Design** when talking about accessibility: all the features of an infrastructure must be usable by everyone, in particular people living with disabilities.

◇ “Are infrastructures marked as accessible only for PwD?” When an infrastructure of any sort (toilets, entrance, desk...) is marked as accessible (with the accessibility international symbol for example), it does not mean that only PwD have the right to use it. As it is stressed in the part concerning universal design, a public accessible infrastructure must be conceived to be **usable by everyone**, with or without impairment.

[International accessibility symbol](#)



The local accessibility planning, a participative process

In order to implement changes to make the general environment more accessible, the local accessibility planning is an important process. **It involves various actors such as local authorities and disabled people organizations** in order to analyze the accessibility of the built environment and to discuss what to do to improve this accessibility. **The involvement of people with disabilities is the key to a successful accessibility planning**, as for bringing them knowledge, empowering them but also having their opinions on the works to be done. By involving them in the process of assessing accessibility and how to better it, you will be sure to build an environment which **fits their needs in terms of accessibility**. By taking care of what PwD are saying, a technician may notice simple problems that from his point of view he would not have seen.

As making this local accessibility planning participatory, you will also **raise awareness among the DPOs about the issue of accessibility**, so that they can seize their rights and defend their cause. In particular, assessments are peculiar moments when this participation must be enhanced. Indeed these moments are excellent for information exchange and communication. They allow carrying out a rather precise inventory of accessibility fixtures and can be used as awareness raising tools as well as lobbying tools to local authorities.

All DPOs and partners should agree on a common position in order to speak with one voice and therefore increase chances of gaining support from local authorities. The decision making process should rest upon those affected by the accessibility initiative (the community, people with disabilities, associations) as much as upon those involved in its implementation (specialists of all kinds such as project managers, architects, etc.). **Collaboration in the decision making processes is essential for the satisfaction and success of a such an initiative** and is the responsibility of all stakeholders. Involving the local authorities in the assessment and this decision-making process will allow passing from a sensitization and lobbying approach to a real local development tool.

Prioritization must be the fruit of participatory workshops between DPOs and local authorities. Although PwD and DPO constitute the legitimate decision makers because they are the first affected by such changes, local authorities must be involved in the planning, because they possess most of the time the decision power in the field of construction, city planning, pavements....

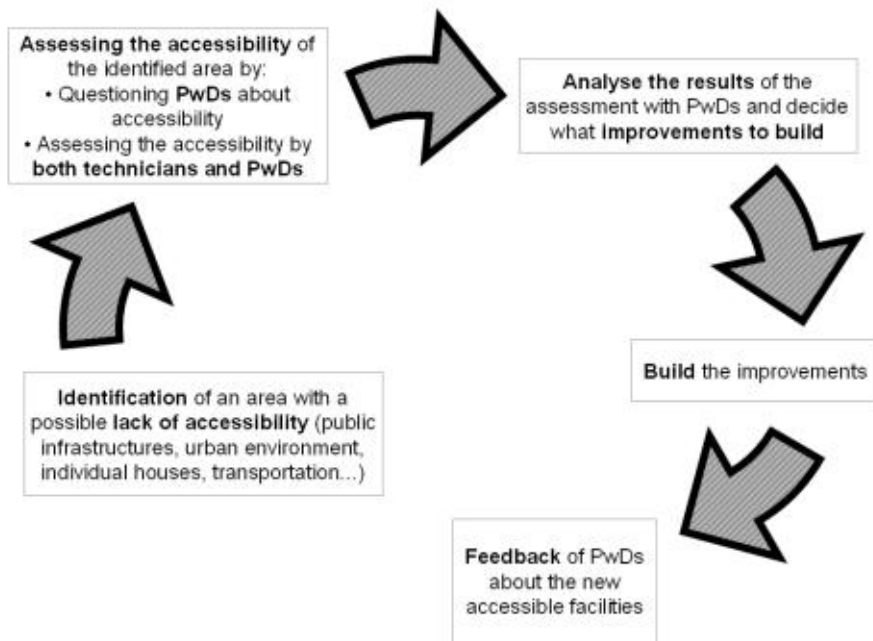

How to implement an accessibility project

Accessibility and UN Convention

Although the Universal Human Rights Declaration theoretically concerns all human beings with no discrimination, people with disabilities often face many physical, technical and social obstacles, and thus do not have the full enjoyment of their basic rights. The Convention on the Rights of Persons with Disabilities, adopted on 13 December 2006 at the United Nations Headquarters in New York, represents a “paradigm shift” regarding attitudes and approaches to persons with disabilities. They are not anymore considered as “objects” (charity, medical attention, social protection) but as “subjects” with their own rights and the ability to claim them. Despite the fact that the Convention does not introduce new rights for people with disabilities, it is a powerful human rights instrument along with an extended social development tool.

Being the object of the first article after the ones enumerating general principles (respect for inherent dignity, non discrimination, full participation in society, respect for differences, and quality of opportunity), accessibility has a place of choice in this convention. According to it, **“States Parties shall take appropriate measures to ensure to persons with disabilities access, on an equal basis with others, to the physical environment, to transportation, (...), and to other facilities and services open or provided to the public, both in urban and in rural areas”**. Thus, both aspects are taken into account:

- On one side, accessibility should concern the physical environment, that is to say buildings, roads, transportation and other indoor or outdoor facilities,
- On the other one, it should also be a part of all information and communications services.

According to the convention, this inclusion of accessibility at national level has to be done leading to different actions:

- By promoting and monitoring the application of minimum accessibility standards in public buildings,
- By ensuring that private entities that provide public services or facilities take into account accessibility,
- By providing training for relevant stakeholders in the field of accessibility,
- By providing appropriate signage and live assistance in public buildings,
- By promoting the access for PwD to new information and communications technologies and systems,
- And finally by ensuring that accessibility is taken into account at early stage to reduce the cost.

Handicap International approach

In the field of accessibility, Handicap International uses a **pragmatic approach**. But before taking any action in favor of accessibility, it is mandatory to be informed about the **national legal framework**. It will allow you to orientation actions towards:

- The application of existing laws or,
- Claiming for a legal framework or the improvement of existing frameworks, when no legislation in favor of disabled people's rights or against discrimination has yet been adopted in the country.

When national laws and standards do exist, it is very important to make sure that they actually are being **correctly implemented**. Effective enforcement of the legal framework can be obtained by:

- Supporting the creation of local accessibility commissions (with disabled people among its members) to check that accessibility standards are being respected in new construction projects and/or to validate constructions once the work is over,
- By offering technical advice to explain clearly and simply the laws and standards and how they should be implemented.



We are about to introduce the Cambodian legal framework, after which we will elaborate a little the international standards on accessibility, to end with a quick presentation of the standards promoted by HI for building accessible public facilities.

Cambodian legal framework

Although there is no specific law or standard in Cambodia concerning accessibility, several existing draft versions are mentioning it more or less deeply. Below are summed up the most important ones, which hopefully will give birth to a strong legal framework in Cambodia in a near future.

Draft Law on the Protection and the Promotion of the Rights of Persons with Disabilities

This law, drafted by the Ministry of Social Affairs, Veterans and Youth Rehabilitation, is may be the most promising one. It mentions accessibility in the general framework of the protection and promotion of the rights of persons with disabilities within the Kingdom of Cambodia.

Among all the articles (59 in total) constituting this law, one chapter (6 articles) is focused on the **theme of accessibility**. The first article of this chapter stipulates that “All public places shall be made accessible for persons with all kinds of disabilities [through installation of features] such as ramps; accessory rails in the bathroom, and signs”. A public place being defined as “any premises, location or building and means of transportation in either state or public or private ownership who provide services widely to the general public such as ministries, departments, institutions, leisure and cultural centres, sport centres, recreational resorts, educational establishments, hotels, hospitals, health centres, restaurants, and transportation networks”. So, once this law will be adopted, the urban environment, public buildings as well as the means of transportation should be made accessible.

Once voted in, the law will be a way to enforce accessibility more broadly in Cambodia and making more public spaces accessible for ALL. .

Draft Accessibility Guidelines by the Disability Action Council (DAC)

This document provides Cambodia with a set of standards on how to build an accessible environment. It focuses mainly on the accessibility of public buildings, offering standard dimensions for car parks, ramps, entrances, doors, corridors, stairs, bathrooms, and toilets, while giving some clues about how to conceive an accessible urban environment (essentially about footpaths and curbs). What would need to be further developed is that the guideline is focusing foremost on accessibility mainly for persons with reduced mobility. So far the accessibility guideline has forgotten most of the time accessibility for persons with visual, audio and intellectual impairments. Despite this paper, more advocacy needs to be done, since public authorities have taken too few actions after this initiative.

Other documents

Some other official documents may mention accessibility as a right to be granted to PwD. We can for example cite the **Policy on Education for Children with Disabilities** from the Cambodian Ministry of Education, Youth and Sport. In this policy, you find on page 6 that one of the main strategies to provide an inclusive education mentions the necessity of “barrier-free infrastructures for accessibility” (strategy #3: ‘provide the opportunity for, and implement, an inclusive program education’). The strategy #5 (‘raise awareness about understanding of disability’) also mentions accessibility as an objective: “provide specific information about infrastructure for school accessibility, e.g., ramps, toilets, playgrounds for children with disabilities, to provincial and district offices of education, cluster schools and schools”. According to this document, schools should be made accessible to children with disabilities, but it is still very rarely the case.

We can pinpoint another document that includes accessibility in its recommendations, the final draft of the **‘National plan of action for persons with disabilities including Landmine/ERW survivors 2008 – 2011’**. Accessibility is mentioned several times, for instance as in

requesting the accessibility of health care facilities or the accessibility to the means of socio-economic benefit.

International standards

Before talking about international standards, we must insist on the fact that such international standards are mainly one way out of many to shape reality. Despite the fact that they exist, the technician who wants to use them would need to adapt them carefully to the specific context in which he/she is. Indeed accessibility can greatly depend on the environment you are working in (economic, cultural...). So no standard should be applied per se but always thought about and adjusted to the context you are in.

All main International standards are summed up in one document produced by the International Standardization Organization (ISO). ISO is responsible for deriving from various national standards (construction sector, but also electronics, quality, environment, and many more) to one unified international standards. Concerning accessibility, the document that has been produced is called "**ISO/TR 9527 – Building construction – Needs of disabled people in buildings – Design guidelines**". It constitutes rather a set of different guidelines than standards to be strictly applied. Several themes are taken up, from the buildings layout to the outside urban environment.

However, we must stress upon the fact that these international standards are quite old (the ISO/TR 9527 was published in 1994 and was not updated since), and the vision of both impairments and accessibility has much evolved since.

“Standards” used by HI for the built environment

In this part, we will present the different standards used by Handicap International in terms of accessibility. These standards are meant as a set of guidelines that **must not be used without adapting them** to the context where you are. They are the result of a combination of various national standards and the experience of HI in different developing countries. What is presented here does not have the pretension to be exhaustive, but aims to give you, the reader an idea of what we mean by ‘accessible environment’.

Access ramps and handrails

As the ramp is the most inclusive way to have access to a building, if there is enough space, it should be provided instead of a stair. To make it accessible, **the slope must not exceed 8%**, knowing that the ideal slope is 5%. The ramp surface must be firm and not slipping, with **tactile surfaces** upstairs and downstairs for visually impaired persons, with in addition a **colored marking**.

Type	Slope	Maximum length
Smooth slope	< 5%	12 m
Medium slope	5% - 8%	6 m
Steep slope	8% - 12%	3 m
Extra steep slope	> 12 %	50 cm

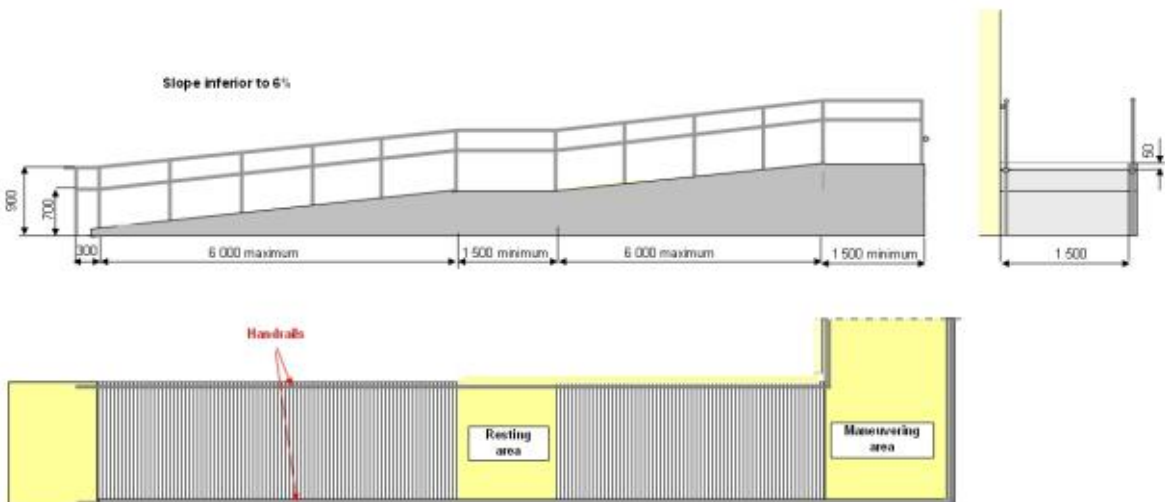

For an extra long ramp, **resting areas** must be provided every 6 meters in order to allow the user to take his breath. They also ought to be provided at each change of direction or in front of each door in order to maneuver. These resting areas should be at least 150 cm long.

Handrails should be provided on both sides of the ramp in order to help people with reduced mobility (who will use them as a help to move) as well as visually impaired people (who will use them as a way of orienting themselves). There should be both a rail at a height of 90 cm (for adults) and a rail at 70 cm (for children and people of small size). The shape of handrails should be cylindrical in order to facilitate the grasp (diameter between 40 and 50 mm). A **side rail** should also be provided at ground level (height between 5 and 10 cm) in order to prevent the wheels of a wheelchair to get out of the ramp.

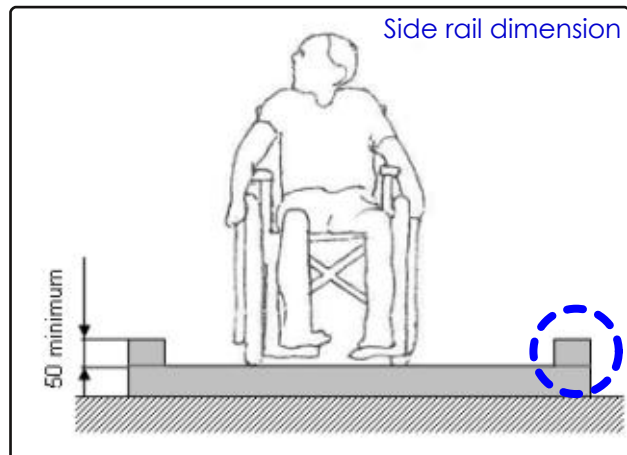
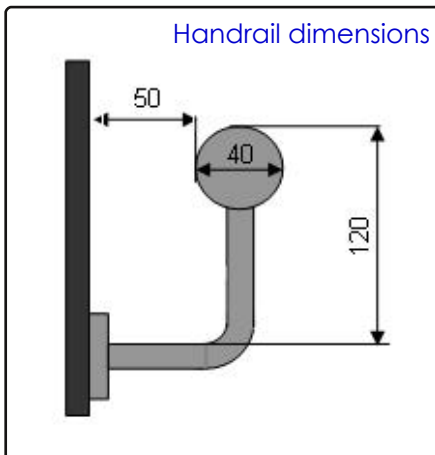

Note

Handrails are mandatory if the height of the ramp exceed 40 cm in order to avoid the falling risk.

Building entrance

For building inclusive facilities, the accessible entrance of any building should be **the main entrance used by everyone**. This entrance should be coherently placed considering the paths that lead to it (from the street, from another building, from the parking area....), and be easily located by the use of vivid colors and **appropriate signage**. Sufficient space should be found in front of the doors in order for the wheelchair users to open them (at least a square of 1,40m x 1,40m).

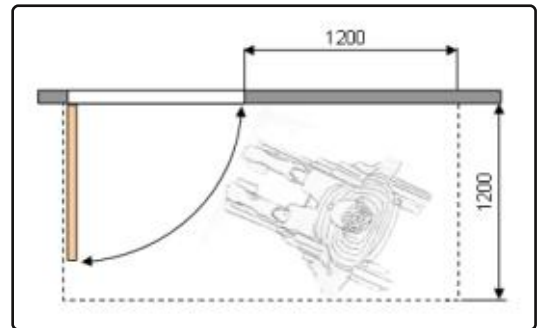
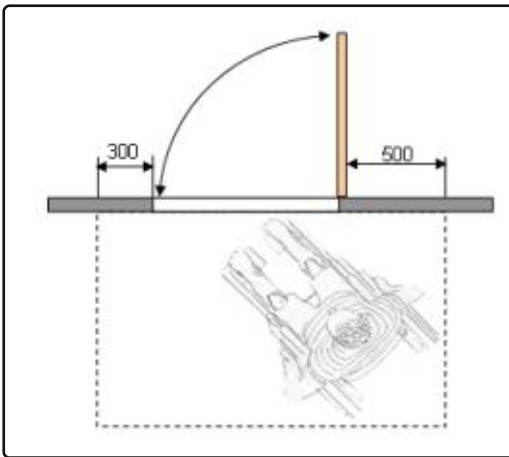

Entrances with sufficient space to maneuver

Doors and corridors

In a general way, persons who have the most difficulties to use the doors are the wheelchair users. Thus you have to think mainly about them when designing these doors. First of all the dimensions of the doors must be adapted: **the width must be of at least 90 cm**, and height at least 2 m. There also must be a sufficient space near the door to permit wheelchair users (and other people with a restrained mobility) to maneuver easily. If possible, **thresholds must be avoided** to facilitate the transition between two rooms. However, if this cannot be done, the threshold must be of a maximum height of 20 mm.

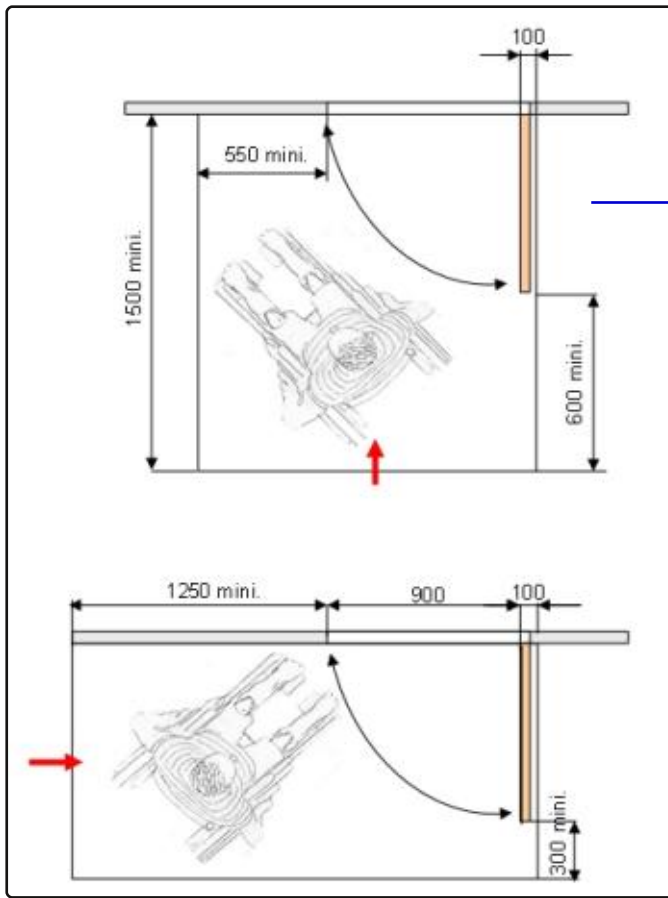

Mandatory maneuvering areas

Door handles must be chosen to be easy to grip and to use, even for those who don't have the use of their hands. An additional handle can be added in the center of the door to help wheelchair users to maneuver more easily. These handles must be found at a height between 80 cm and 90 cm to be accessible to children, wheelchair users and people of small size.

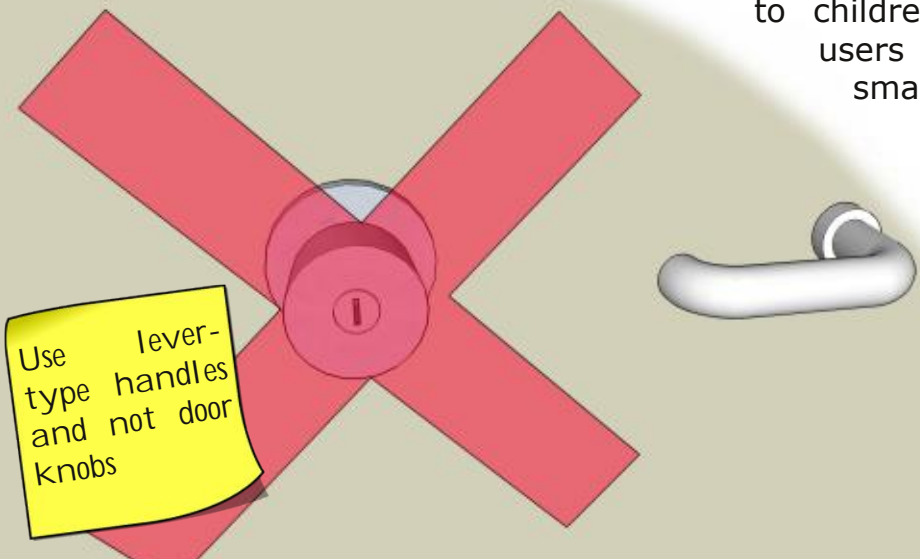

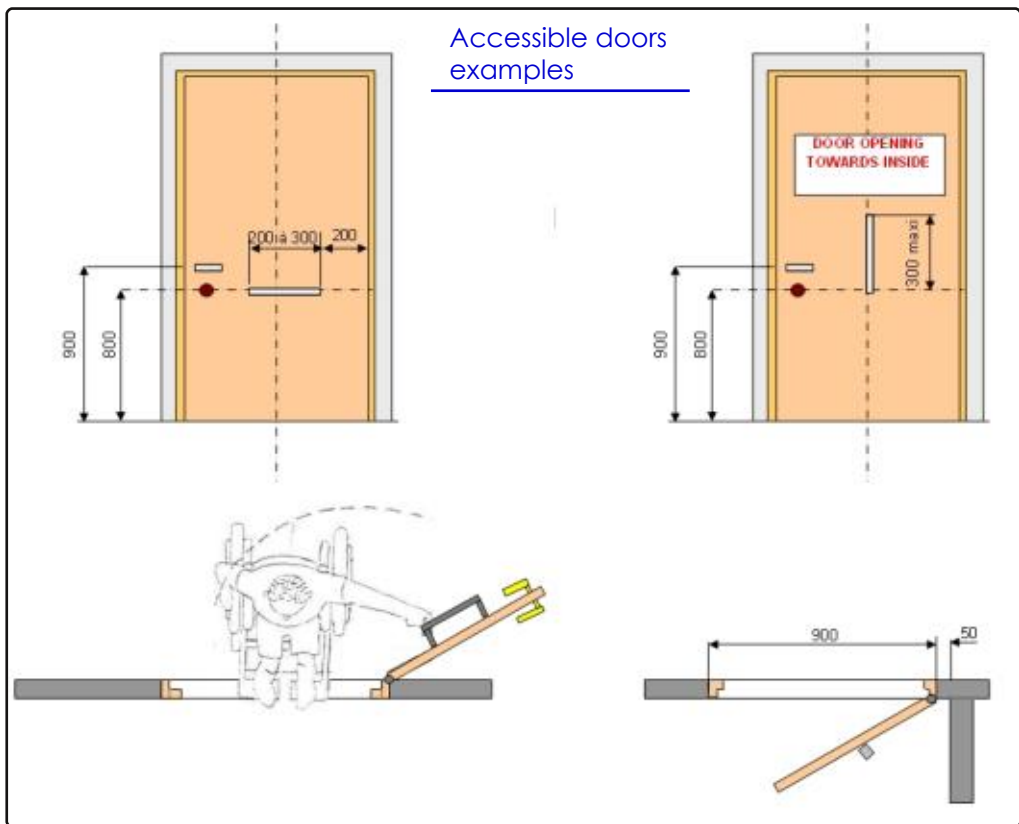

Concerning the corridors, this is quite simple: **they must be wide enough** to let the traffic flow (at least 140 cm – 190 cm if the place is much frequented). There must be neither obstacles in the pathway nor hanged on the buildings (height superior to 2 m). If threshold are necessary, they must not exceed 20 mm high.

Stairs

Even if they are not accessible to some people with reduced mobility (including wheelchair users of course), stairs are sometimes **the only alternative to have access to upper floors** (building a ramp can be impossible, and elevators are expensive). That is why a particular attention must be paid to **make them fully accessible**. Some simple layouts can be used to build an accessible stair:

- All the steps in a staircase should have the same dimensions to avoid hazards, with no protruding step noses or open spaces between steps,
- The width of a step must be at least 28 cm, whereas the height of it must not exceed 16 cm,
- Textural marking strip should be provided at the top and bottom,
- Noses of step should be marked with contrasted colors and preferably different texture,
- And handrails should be provided on both sides of the stair, respecting the same standards as for the ramps (cf page 25).

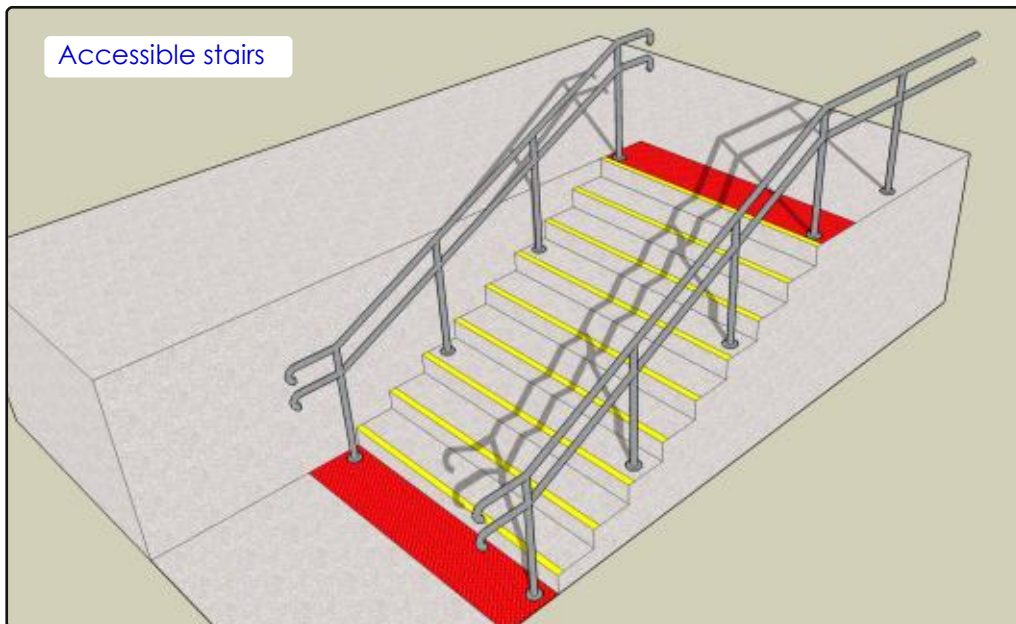

Toilets

Before developing the accessibility of the toilets building itself, it is important to underline the fact that they must be easy to access (the corridor leading to them must be accessible, as well as their door). The most important thing to think about is to **provide sufficient space to maneuver** easily inside them: a free area (of a size of at least 80 cm x 130 cm) must be available next to the toilet seat for a wheelchair user to be able to transfer himself from his wheelchair to the seat. If possible, **a free circle of 1.50 m** should be provided so that a wheelchair can make a complete turn.

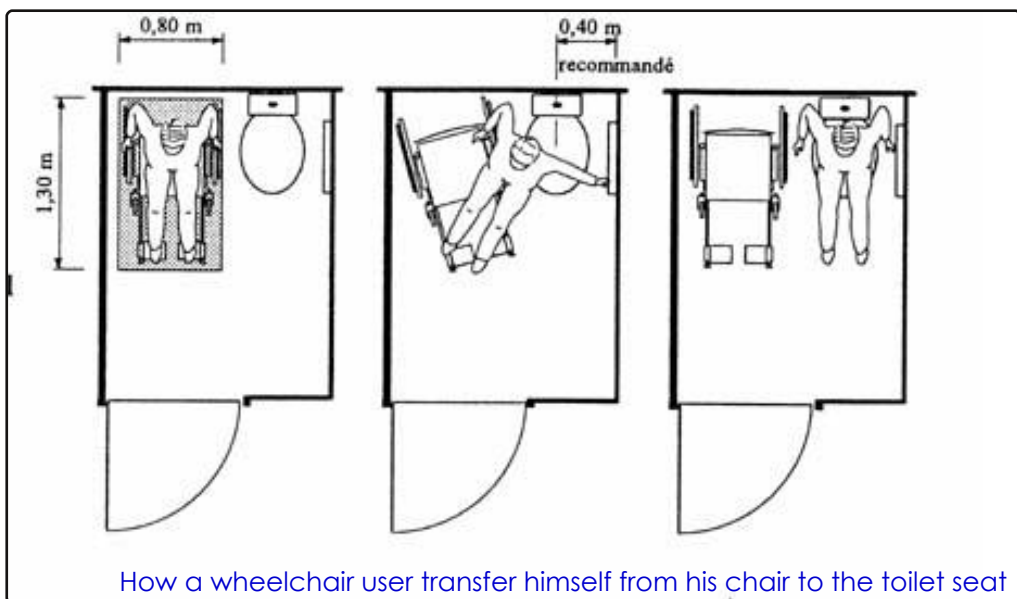

Concerning the seat, it should be around 50 cm height, and equipped with some **lateral rails to help for the transfer from a wheelchair**. Washbasins, soap, hand driers, mirror, towel or paper dispensers... must be usable by wheelchair users. Taps should be easy to access and to grip. Floor should be non slippery in order to avoid accidents of many sorts.

Pathways, sidewalks and curb ramps

It often happens that pathways and sidewalks, which must be ways for the people to move along, are completely non-accessible: the road surface can be uneven, there can be obstacles and obstructions in the way, and most of the time there is an important lack concerning signalization and warnings. The objective is to design pathways and sidewalks that **will allow the user to safely and independently move around**.

To reach this objective, there are some prescriptions to respect. **The minimum width of an unobstructed pathway should be 0.90 m**, but the preferable width is 1.80 m (the minimum width of a two-way wheelchair traffic passage is 1.50 m). Concerning the surface of the pathway, it should be **smooth, even** (the size of holes and bumps should not exceed 20 mm, or else the front wheels of a

wheelchair will jam), **continuous and non slippery** (even when it rains). To be comfortable and safe, pathways also shouldn't be banked with a gradient higher than 2%.

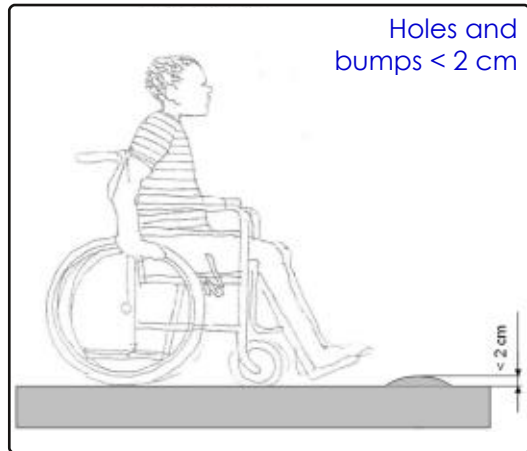
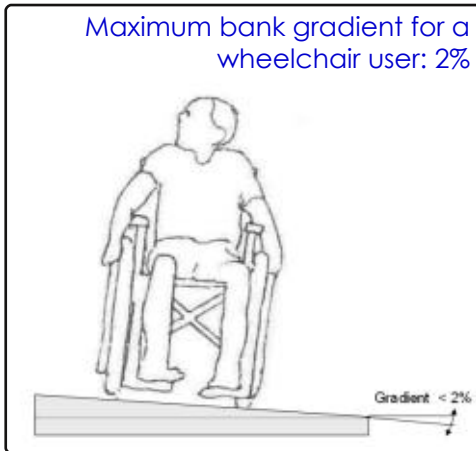

In order to help people with a visual impairment, **guiding stripes** should be built along the different pathways and sidewalks. Guiding stripes can be either a straight continuous line of detectable natural objects and defined edges (i.e. building frontages, grass verges, raised platforms, continuous railing, curbs, guards, low barriers, etc.) or a colored stripe of a different texture and different color than the pathway itself (like using a some colored and textured tiles to make a stripe along the pathway – see picture below). Guiding stripes should be laid in **a simple and logical manner** and should not be located close to manholes or drains to avoid confusing sightless people.

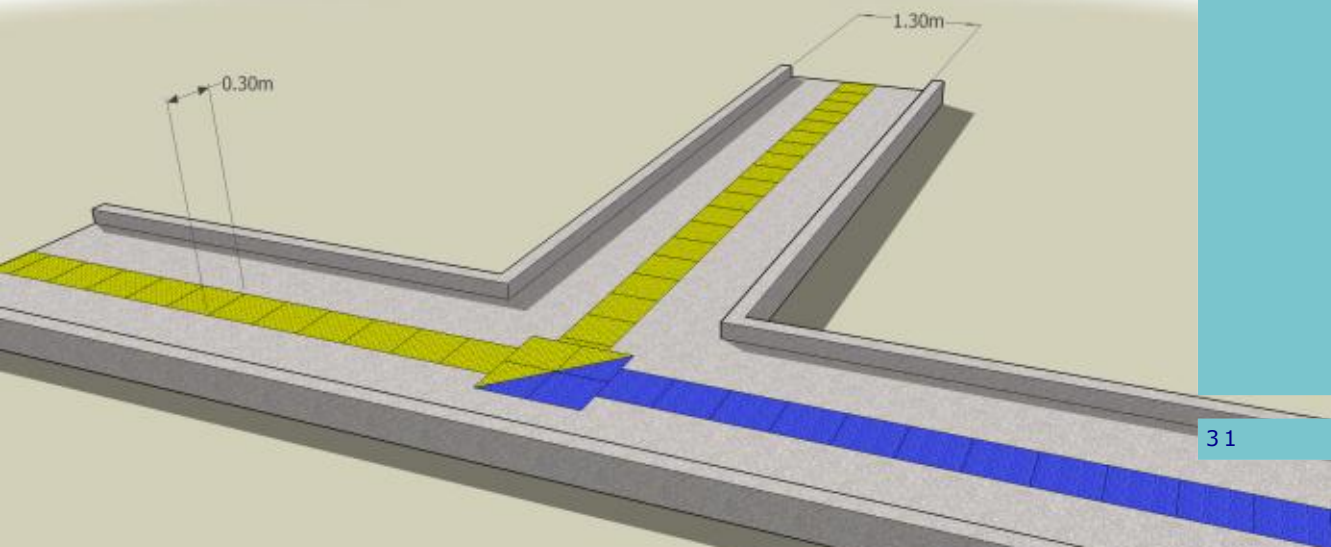

In the same way of thinking, around each change of direction or each obstacle, **tactile markings (a ground surface with a different texture)** should be put in place. They also should be used in front of each pedestrian crossing.

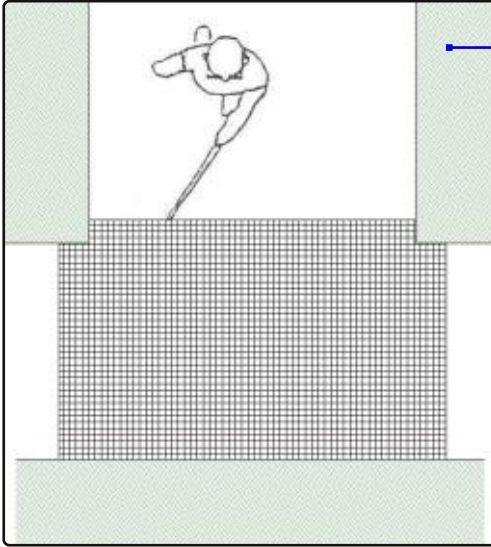

Textured marking at a crosspath

Regarding the sidewalks, it is common to have no transition at all between them and the road, resulting in preventing some users (in particular wheelchair users) from moving along these sidewalks. Thus, it is important to overcome changes in level between

the pavement and the road surface and also on the pavement itself, which is done by constructing a **curb ramp each time it is necessary** (at each pedestrian crossing for example). Pavement should be lowered, at a maximum slope of 8%, to provide the necessary level transition, and the minimum width of a curb ramp should be 0.90 m, excluding the sloping sides. The recommended width is 1.20 m.

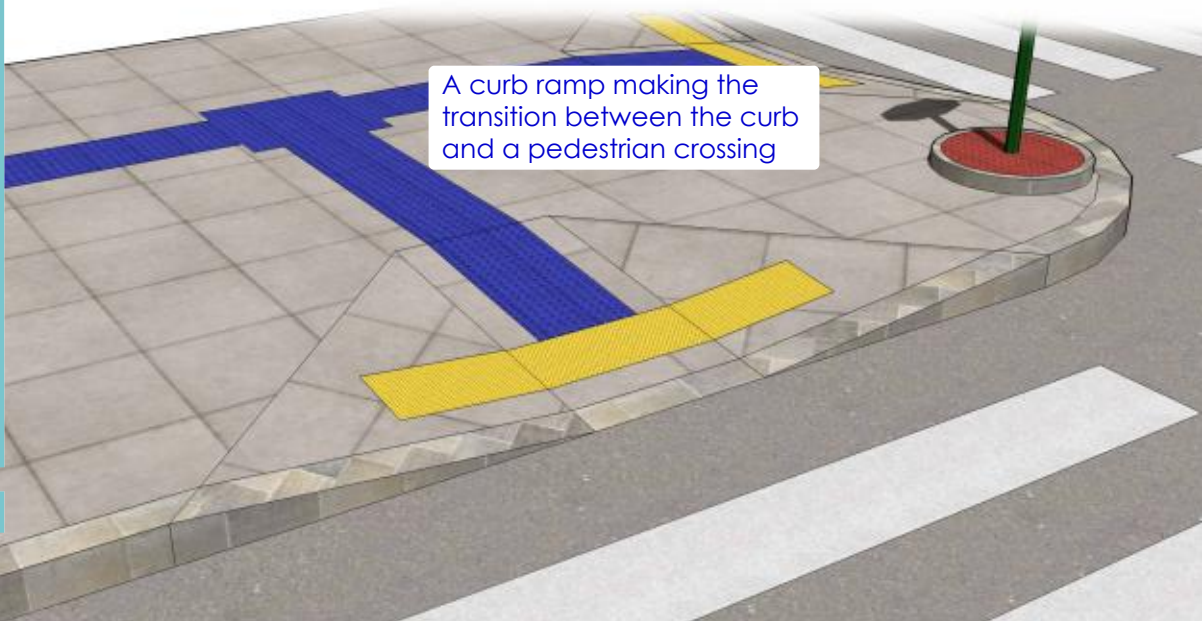

A curb ramp making the transition between the curb and a pedestrian crossing

Obstacles and street furniture

An important and common accessibility issue is that **pathways and sidewalks are usually full of various obstacles** (street furniture, traffic signs, direction signs, street plans, bollards, plants, trees, shop awnings and advertising signs, etc) which can prevent the user from moving safely and independently.

The objective here is to design a **barrier-free path** for the safety and independence of people with disabilities, especially the persons with a visual impairment. **Obstructions should be placed outside the path of travel** wherever possible and protruding elements should be avoided. Obstructions in the pathway should be easy to detect, and if possible, should be placed along one continuous line and protruding elements should be avoided.

Obstructions on the pathway surface should have one of the following three design features in order to be **detected by the cane of a sightless person**:

- A straight shape rising from the pathway surface
- A 0.10 m raised platform
- Tactile warning markings on the ground around the obstruction

It is better to install **wood or plastic furniture**, and favor smooth forms, in order to minimize the risk of accident in case of collision. Obstacles must also be marked by a contrasting color, in order to help visually impaired people to detect them.

Concerning overhanging obstacles, they should be hanged at a minimum height of 2 meters. If it is not possible, a special feature should be put in a place in order to warn blind people of its presence (raised platform, shape or tactile warning markings on the ground).

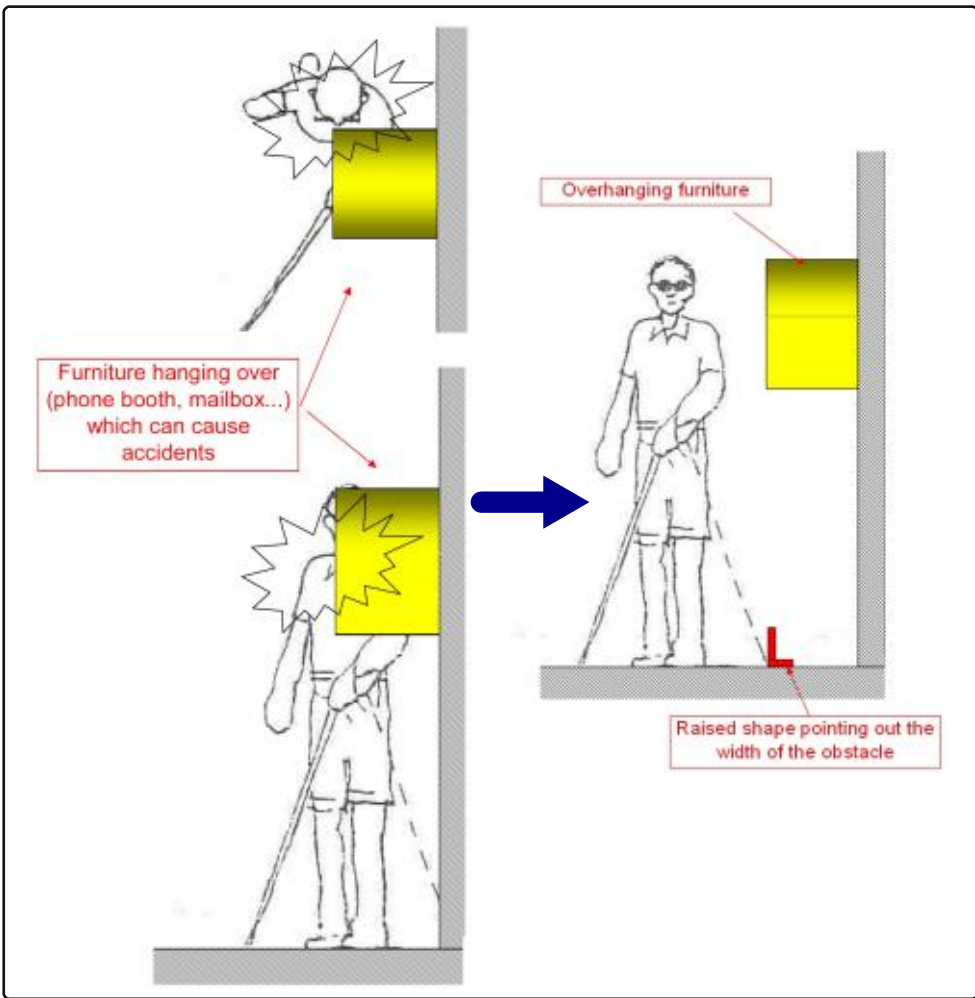

Signalization

The signage includes direction signs, indication signs in and out public buildings, but also all the panels that one can find within the urban environment (names of the streets, of the cities, directions, information signs...). **A good and adapted signalization is mandatory**, improving the orientation of everyone. It prevents from making useless displacements and moves.

For **public buildings**, this signage is made of:

- An adequate indication of the main (accessible) entrance.
- An orientation map near this entrance.
- Information about the main equipments and services provided in the building.

Urban signage must be clear, easy to read and to understand (avoid glass panels and favor contrasted colors). **Too much information kills information.** Relief prints are advisable: the letters and signs should preferably be raised at least 1 mm from the background, to enable sightless people to read the information using the tips of their fingers.

Accessible places and facilities should be clearly identified by the international accessibility symbol:



Standardised vs. individualised approach

To conclude this manual, it is very important to stress upon one fact concerning this set of booklets. Indeed, we have developed above the set of standards used by Handicap International in order to build accessible public buildings and more generally an accessible urban environment. However, the case of individual housing (and other individual spaces like workspaces) can be **very different**.

For individual housing, one must not so much rely on national or international standards but much more on the **specific needs of the disabled person** that is living (or will occupy) in the house or in the apartment. Every disabled person needs a special and individual adaptation at home: the individual situation will determine what accessibility features are required in order to make the housing fully accessible and functional.

Personal adaptation can be made after an individual evaluation. This individual evaluation must be made by a professional (for example occupational therapist). Any adaptation work must be done in a dialogue between the occupant (owner or tenant), a helping professional and/or project manager (architect, civil engineer...).

Individual evaluation example

You will find below an example of an individual evaluation that can be made for assessing the needs of a person with a reduced mobility. This evaluation must be carried out by a professional in close collaboration with the occupant.

- ◇ Identity, family situation, general situation:
 - o Name, impairment, family, personal helper...
 - o Use of walking aids: wheelchair, walker, crutch, tripods, stick...
 - o Activities: with family, friends, sports, artistic, job...

◇ Range of movements evaluation:

The range movement evaluation is looking at the movement that the person is able to do (actively or passively) with different parts of the body: head, shoulders, elbows, wrists, thumbs, fingers, hips, knees, ankles, toes.

◇ Prehension evaluation (the capacity to grasp objects)

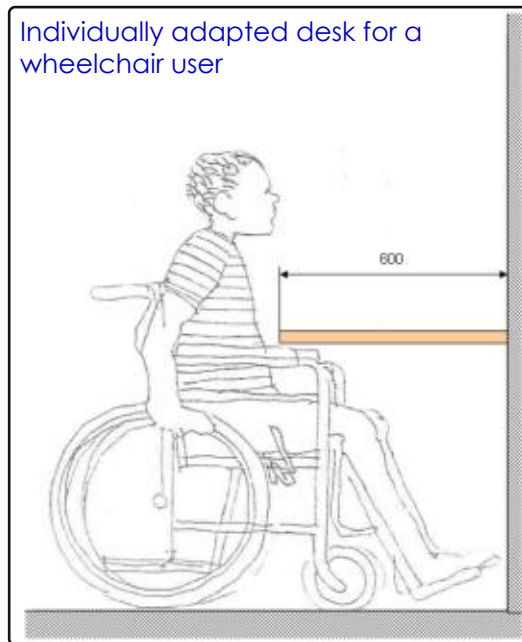

In the three technical manuals that are following this one, you will find some suggestions of accessible facilities (toilets, showers, water pumps, access ramps...) that are in most cases designed to be used by the whole community. **Nevertheless one must never forget that in individual cases, the most important thing is to discuss the needs of the person and find the most adapted solution(s).**

References

Bill Albert, on behalf of ODG – DEV, Lessons learnt from the Disability Knowledge and Research programme, DFID – ODG – DEV, 2006

DCDD Program. Position Paper, Say Yes to the ratification of the UN convention for the Rights of people with disabilities, Dutch Ministry (consultation November 7, 2008), <http://www.dccd.nl>

UK Government. (consultation November 7, 2008). Internet site [on line] http://www.direct.gov.uk/disabled_people

Disability Action Council (consultation November 7, 2008). Internet site [on line] http://www.dac.org.kh/disability_in_Cambodia

Disability Action Council, Cambodia, Accessibility Guidelines – Draft, March 2000

Communities and local Government, Planning and Access for disabled people: a good practice guide, UK Government, © Crown, March 2003

United Nations, Convention on the Rights of Persons with Disabilities and Optional Protocol, 2006

Ministry of Social Affairs, Veterans and Youth Rehabilitation, Cambodia, Draft Law on the Protection and the Promotion of the Rights of Persons with Disabilities, January 2008

Ministry of Education, Youth and Sport, Cambodia, Policy on Education for Children with Disabilities, March 2008

KINGDOM OF CAMBODIA, National plan of action for persons with disabilities including Landmine/ERW survivors 2008-2011, Final Draft, September 2008

Jones, H.E. and Reed, R.A., Water and Sanitation for Disabled People and Other Vulnerable Groups – Designing Services to Improve Accessibility, WEDC, Loughborough University, UK, 2005



**Handicap International
French Section Head Quarters**

14, avenue Berthelot,
69361 Lyon cedex 07, France

Tel: + 33 (0) 4 78 69 79 79

Fax: + 33 (0) 4 78 69 79 94

E-mail: contact@handicap-international.org

Internet: www.handicap-international.fr

Cambodia Program

#6, St. 348, BKK3

Chomkarmon, Phnom Penh

Tel: +855 (0) 23 212 897 / 214 504

E-mail: office@hicambodia.org